



ATSUMOTOR



管式精密電機

可搭配各式電動自行車

2021

CONTENTS

管式電機簡介	3
管式電機規格	4
馬達可以交換	5
馬力供應系統	6
配件-螢幕配件	7
配件-電池配件	8
配件-車件配件	9
智能曲柄選配	1 1
車子照片花絮	1 2



— WELCOME TO ATSU-MOTOR E-BIKE WORLD —

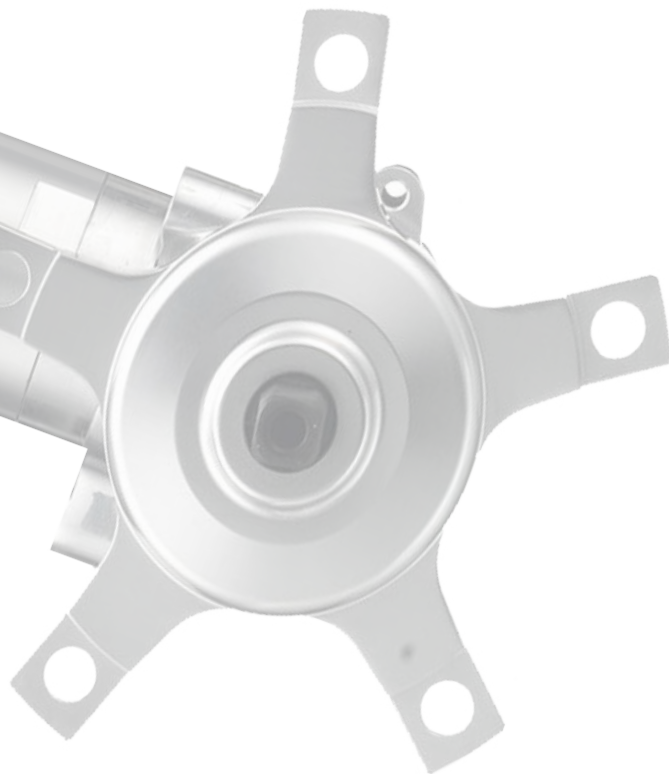

隱形管式電機可全方位 解決美觀和性能問題

電動助力車的最佳化設計就是隱形式的馬達可置入下管或座管內完全隱藏在車架內ATSU-MOTOR的設計是有雙離合器和助力傳感器，當騎乘者切換成一般自行車模式時，可以感受輕鬆自如另外ATSU-MOTOR的馬達可以搭配不同的馬力輸出，讓自行車可以有不同的爆發力，助力模式電力的大小，管式馬達讓每位騎乘者都能夠自由且安全舒適地騎乘電動助力車。



管式電機

電機系統含離合器，在無電力供應時，也能踩踏自如

馬達輸出供應建議  200W 折疊車

250W 跑車/登山車

350W 下坡車/登山車



可輕鬆爬坡25 - 30°

型號	TM-4265	TM-4865	TM-5265		TM-5765		TM-6665	TM-6680	
馬達類型	無刷直流馬達								
電壓	36V	24V	36V		36V		36V	36V/48V	
輸出功率	200W	200W	250W	350W	250W	400W	250W	400W	500W
最大扭力	50Nm	50Nm	61Nm	76Nm	61Nm	87Nm	61Nm	87Nm	98Nm
電機重量	2.8Kg	4.08Kg	3.6Kg	3.8Kg	3.7 Kg	4.0Kg	3.7Kg	4.0Kg	4.2Kg
儲放溫度	-20°C ~ 50°C								
速度感應器	標準配備								
扭力感應器	選 配								

TM系列動力系統說明

解說圖

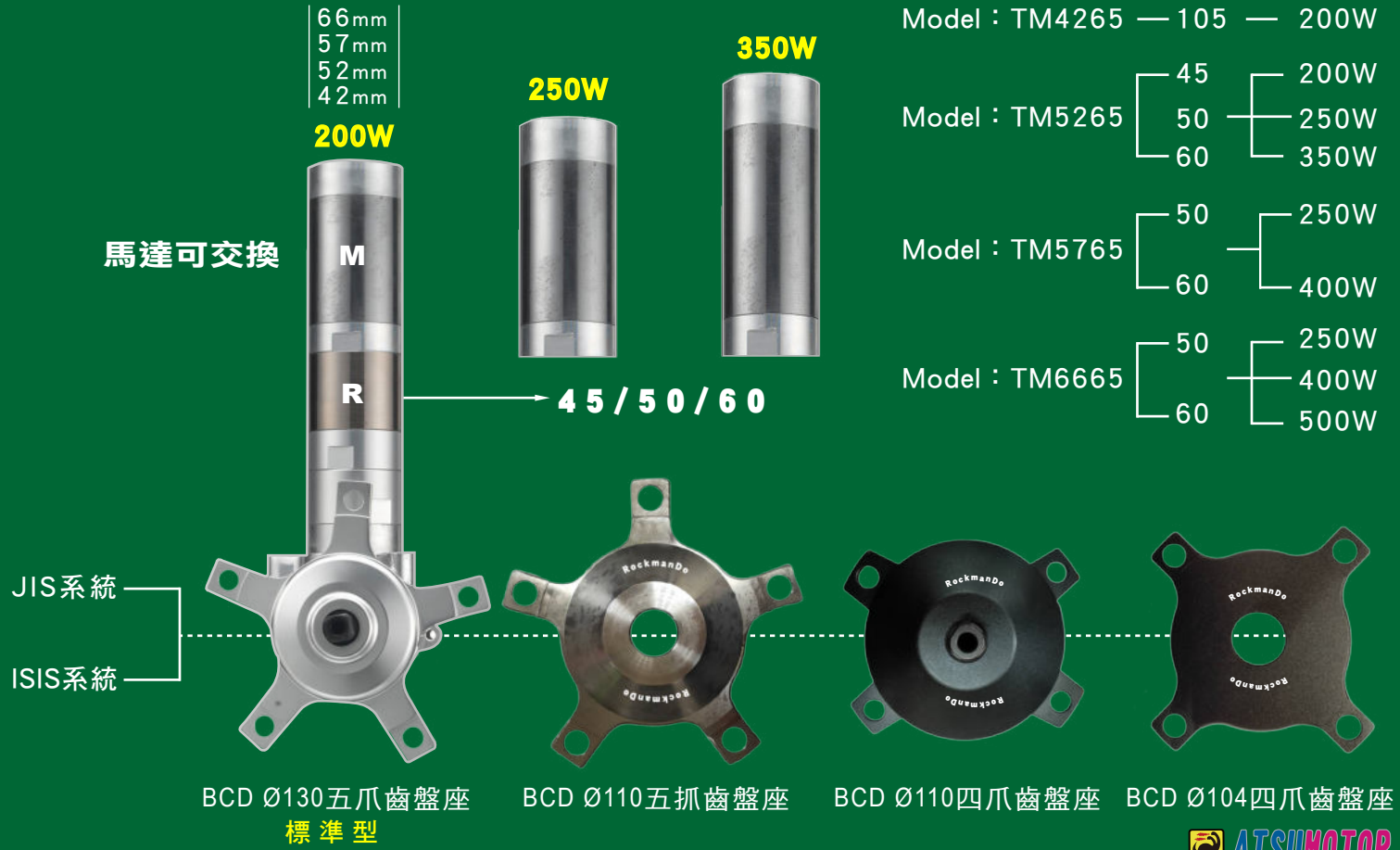

馬力供應系統

馬達置入下管
電動輔助自行車

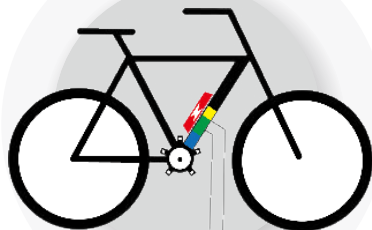

MOTOR & PEDALASSIST
CONTROLLER

馬達置入座管
電動輔助自行車



MOTOR
CONTROLLER

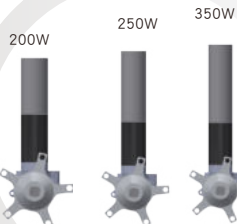

馬達可替換式

電動輔助摺疊車



CONTROLLER
MOTOR &
PEDALASSIST

電動輔助載貨自行車

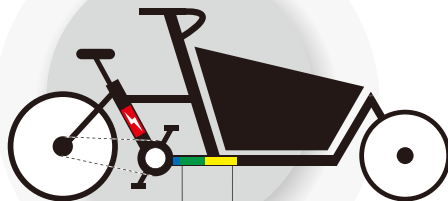

MOTOR &
PEDALASSIST
CONTROLLER

馬達可以更換

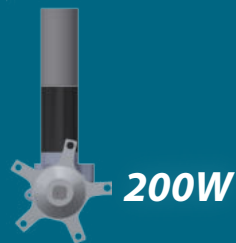

200W

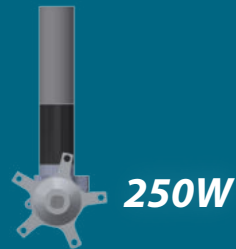

250W

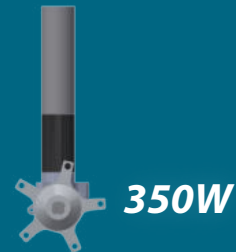

350W





儀表規格

動態面板在進化，提供助力模式 1-5 段多元動能輔助模式，並可快速切換騎行模式，可根據客戶的不同需求進行個性化訂製。

▶ 功率：36V
段數：5段
顯示總公里數

CE EN15194



	<p>DK-01 Size : 1.3 Inch 點陣LCD屏智能儀表。</p>
	<p>DK-02 Size : 2.2 Inch TFT彩色LCD彩色屏智能儀表。</p>
	<p>DK-03 Size : 3.1 Inch 字段LCD屏智能儀表，中置儀表，搭配單獨的遙控按鍵，USB接口充電功能可選。有背光，連按3秒即可。</p>

配件-電池配件



電池規格CE&CB 認證
機芯日本製造。



鋰三元24V/6.8AH
BN2468(24V)



鋰三元36V/6.8AH
BN3668(36V)



鋰三元36V/8.1AH
BN3681(36V)



充電器
CHD01-24V
CHP02-36V

➡ 輸入：AC100V-240V
50-60HZ
輸出：42V-2.0A

☑ 過充/短路安全試驗

☑ 充電系統安全試驗

☑ 溫度循環試驗

☑ 衝擊試驗

☑ 落下試驗

☑ 擠壓測試

☑ certified to CE & CB

☑ 振動測試

☑ 有安全保險絲



淑女車
FCA-01



胖胎車
FFA-01



公路車
FRA-01



公路車
FRC-01



公路車
FRC-02



公路車
FRC-03



登山車
FMA-03



登山車
FMA-03



登山車
FMA-03



登山車
FMA-03



公路車
FRA-K2



公路車
FRA-K2



公路車
FRA-K2



公路車
FRA-K2

智能曲柄選配

Patent #:US10479445B2
智能曲柄的應用程式



滑環

防水接頭 電子感應器

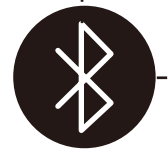
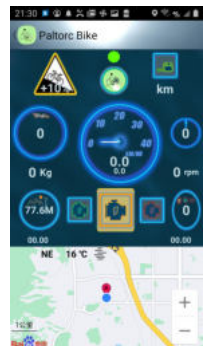
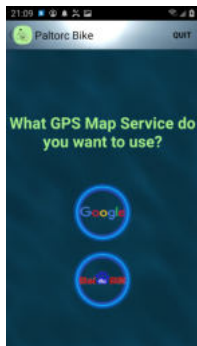

Bluetooth
藍芽



Smart phone
手機

照片花絮



騎乘電動自行車
探索生活和
捕捉漂亮新事物

享受單車生活



ATSU-MOTOR 動力系統是一套電力人力混合系統並且擁有強大的設計部門，和製造團隊讓我們的產品使騎乘者更舒適

紅菱重工股份有限公司

地址:雲林縣斗六市雲科路三段116號

網址:<http://www.honlin-hp.com>

EMAIL: sales@honlin-hp.com

TEL:+886-5-551-1039

FAX:+886-5-551-0028



ATSUMOTOR